

Note:

These exploded views apply only to version 1.0.
The version can be determined from the 9th digit of the
8 number on the nameplate **A** (8.xxx.xxx.x1xxx).

ID	Service parts	S-RS	Description
A-01	6.311.090.001	S	Descaling plug
A-02	6.206.600.001	S	Lid column B 20 / B 40
A-03a	6.205.855.000	S	Electrodes + support B (HW) standard
A-03b	6.305.052.000	S	Electrodes + support B (HW) special
A-04	6.205.850.001	DT	Water tank column B-series
A-05	6.016.008.052	RS	High temperature safety switch
A-06	6.000.247.296	S	Flow boiler B 40

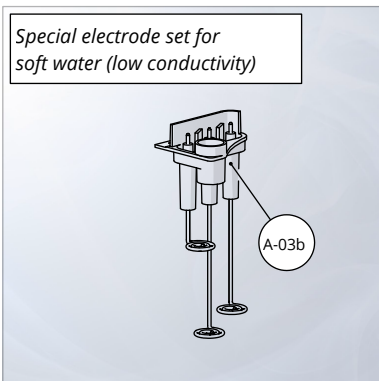
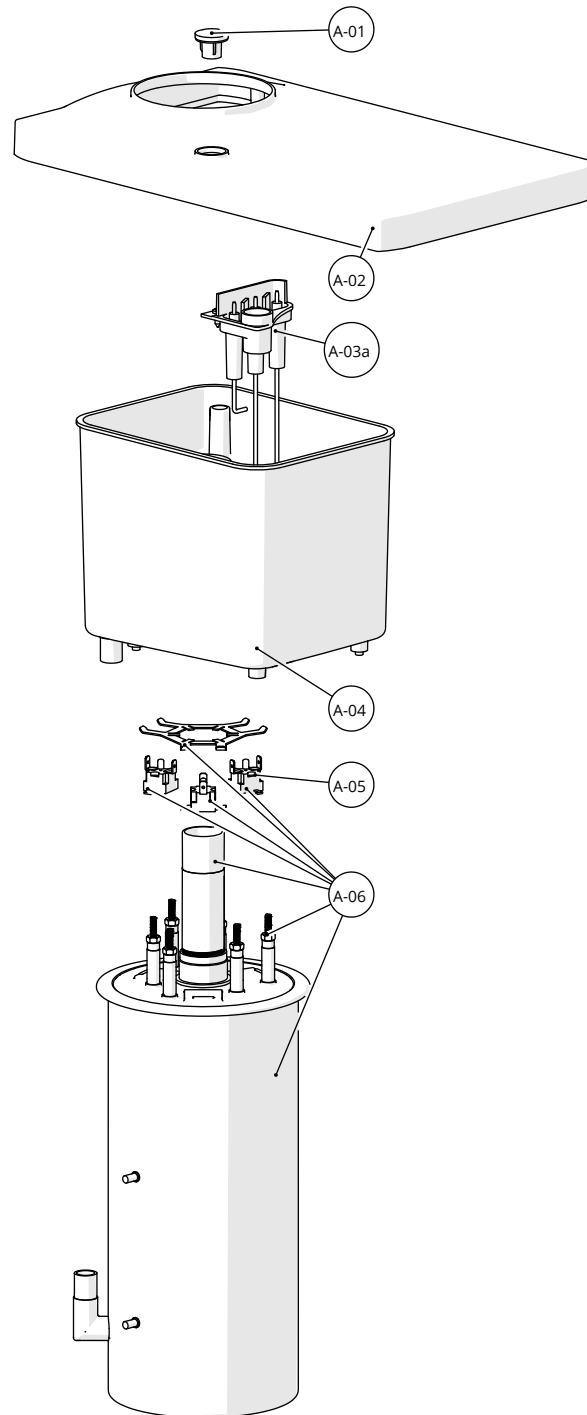

ID	Service parts	S-RS	Description	mm
B-01	6.000.205.111	S	Connection tube 1.5 m	
B-02	6.016.001.078	RS	Magnetic valve 3.8 l/min	
B-03	6.001.079.006	S	Tube clamp 19 mm	
B-04	6.019.033.251	S	Silicone tube 10x2.5	320
B-05	6.016.024.004	RS	Flow meter	
B-06	6.001.079.003	S	Tube clamp 15.6 mm	
B-07	6.019.033.014	S	Silicone tube 9.5x3	780
B-08	6.205.853.001	S	Cover waterinlet	
B-09	6.019.033.013	S	Silicone tube 11.5x3	430
B-10	6.019.033.013	S	Silicone tube 11.5x3	60
B-11	6.019.033.016	S	Silicone tube 25x4.0	230
B-12	6.206.596.000	S	Ascending pipe	
B-13	6.206.589.001	S	Sleeve ascending tube B 20 / B 40	
B-14	6.011.001.061	RS	O-ring 28x4	
B-15	6.017.003.006	S	Magnet swivel arm	
B-16	6.311.098.001	S	Knob swivel arm	
B-17	6.247.303.000	S	Swivel arm B 40 / WDB 40	
B-18	6.019.033.013	S	Silicone tube 11.5x3	260
B-19	6.006.002.014	S	Tightening plug 14.5 mm	
B-20	6.229.760.001	S	Nipple	

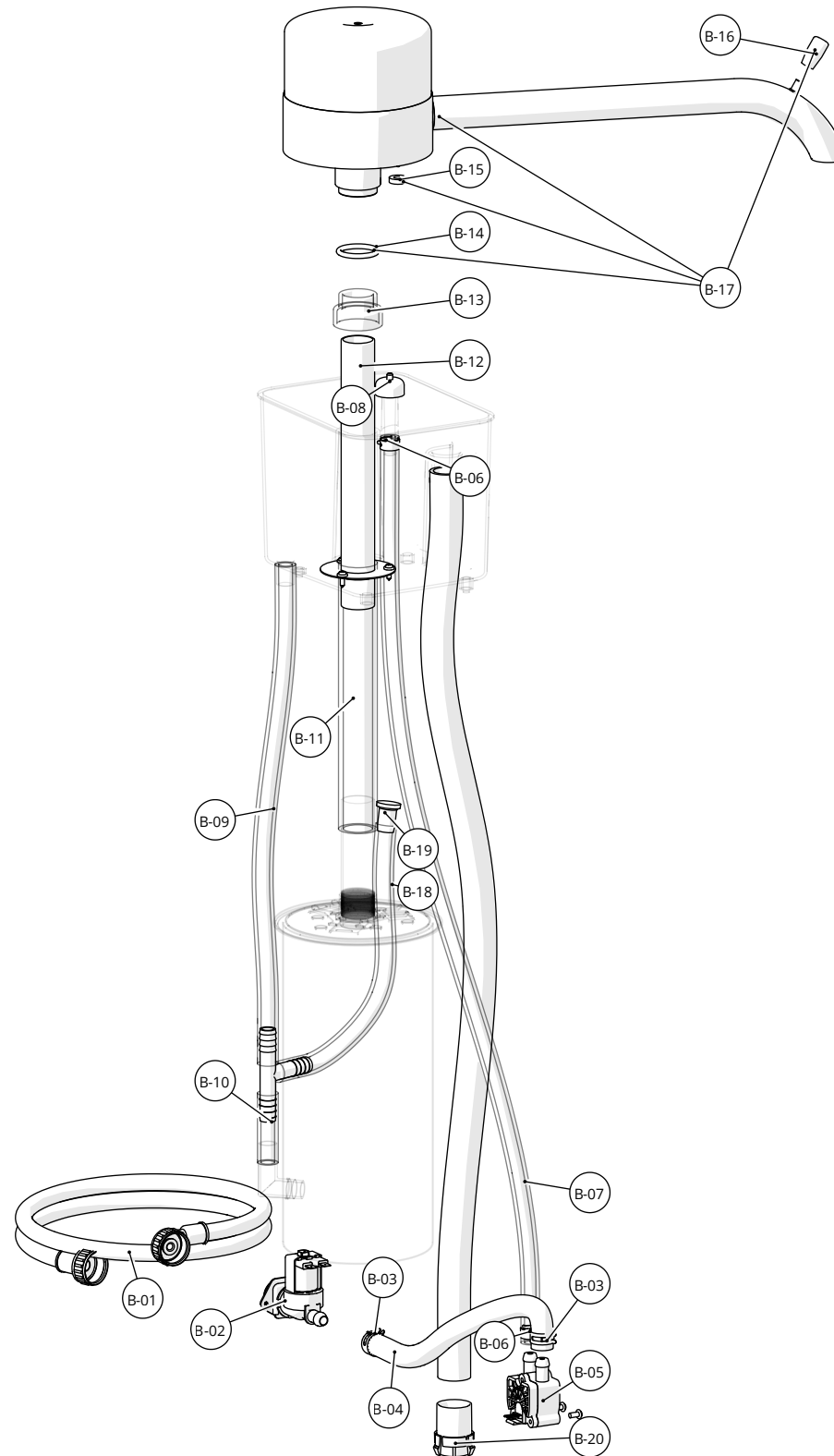

ID	Service parts	S-RS	Description
C-01	6.006.001.039	S	Cord inlet
C-02	6.002.019.160	DT	Connection clamp (400V3N)
C-03	6.211.773.000	S	RC combination
C-04	6.004.008.015	RS	Relay 230V
C-05	6.005.011.027	S	Fuse 2A (10 pcs)
C-06	6.005.012.008	S	Fuse holder
C-07a	6.006.005.100	S	Socket (STD)
C-07b	6.006.005.104	S	Socket (GB)
C-07c	6.006.005.108	S	Socket (DK)
C-08	6.205.865.000	S	Flap for socket left
C-09	6.205.864.000	S	Flap for socket right
C-10	6.401.217.001	S	Adapter switch
C-11	6.004.001.069	RS	Switch
C-12	6.205.859.001	S	Service panel
C-13	6.205.862.001	S	Push buttons
C-14	6.205.860.001	S	Window service panel
C-15	6.247.312.000	S	Reed switch B 40
C-16	6.006.010.055	S	Cable clip
C-17	6.006.010.078	S	Wire clip 10mm

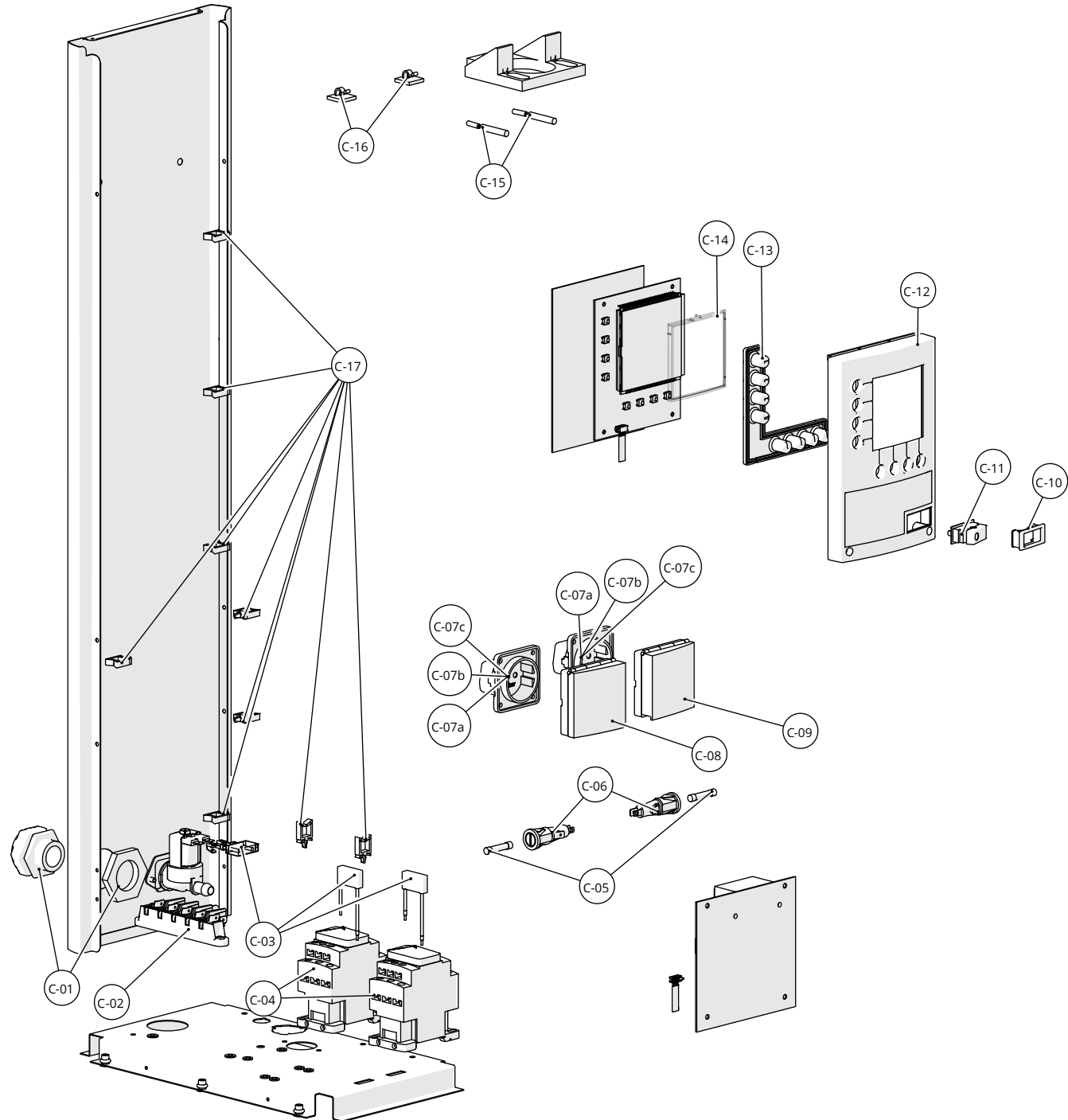

ID	Service parts	S-RS	Description
X1-01	6.205.861.000	RS	Keyboard B (HW)-series
X1-02	6.205.919.000	RS	Flat cable
X1-03a	6.205.873.000	RS	Mainboard B-series (230V)
X1-03b	6.205.955.000	RS	Mainboard B-series (200V)
X1-03c	6.205.957.000	RS	Mainboard B-series (120V)

To the green display X1-01 belong the specific parts X1-02 and X1-03. The parts of X1 and X2 are NOT interchangeable, but it is possible to replace all 3 parts together (X2-01, X2-02 and X2-03) on a machine with a green display. Used till may 2023.

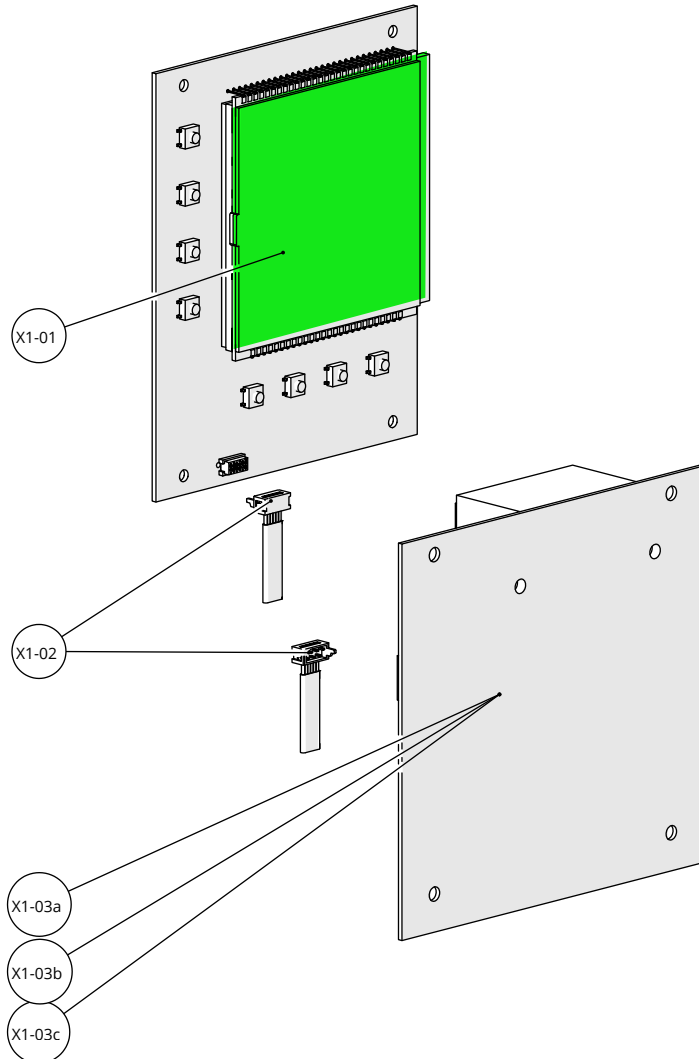

ID	Service parts	S-RS	Description
X2-01	6.305.034.000	RS	Keyboard B (HW)-series
X2-02	6.305.043.000	RS	Flat cable
X2-03a	6.305.035.000	RS	Mainboard B-series (230V)
X2-03b	6.305.037.000	RS	Mainboard B-series (200V)
X2-03c	6.305.039.000	RS	Mainboard B-series (120V)

To the orange display X2-01 belong the specific parts X2-02 and X2-03. The parts of X2 and X1 are NOT interchangeable. Used from june 2023.

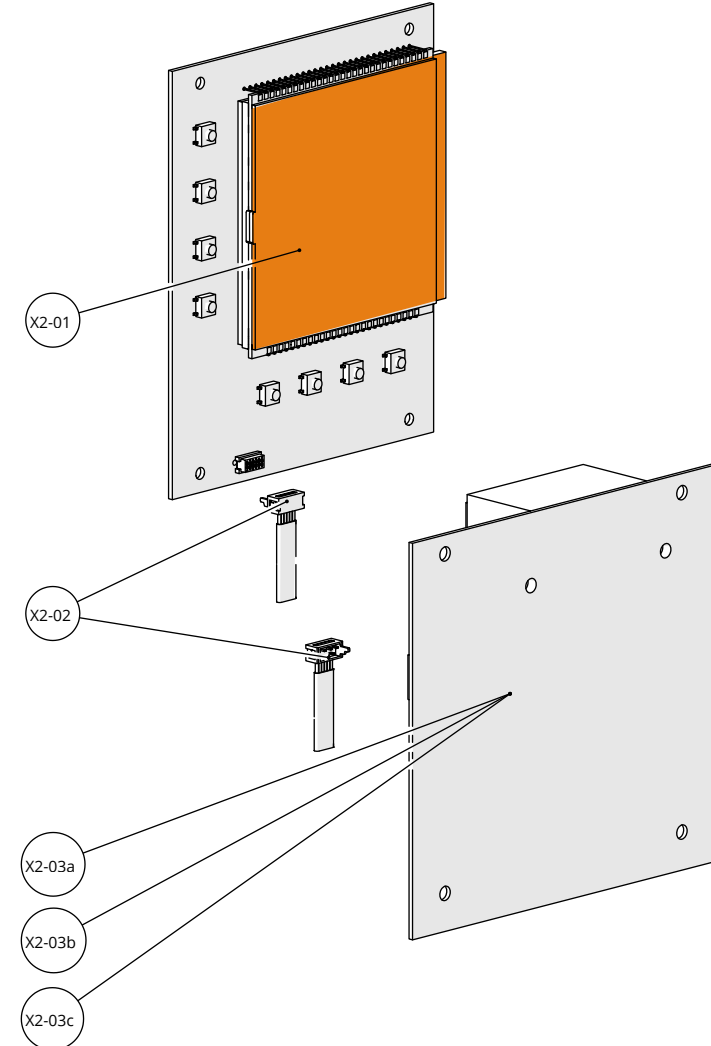

ID	Service parts	S-RS	Description
D-01	6.311.072.001	S	Foot B-series
D-02	6.006.010.084	S	Cable clip
D-03	6.311.218.001	S	Reed switch safety
D-04	6.206.630.000	S	Reed switch
D-05	6.311.126.001	S	Cam
D-06	6.311.204.001	S	Sealing ring base B-series
D-07	6.311.203.001	S	Cap reed contact switch

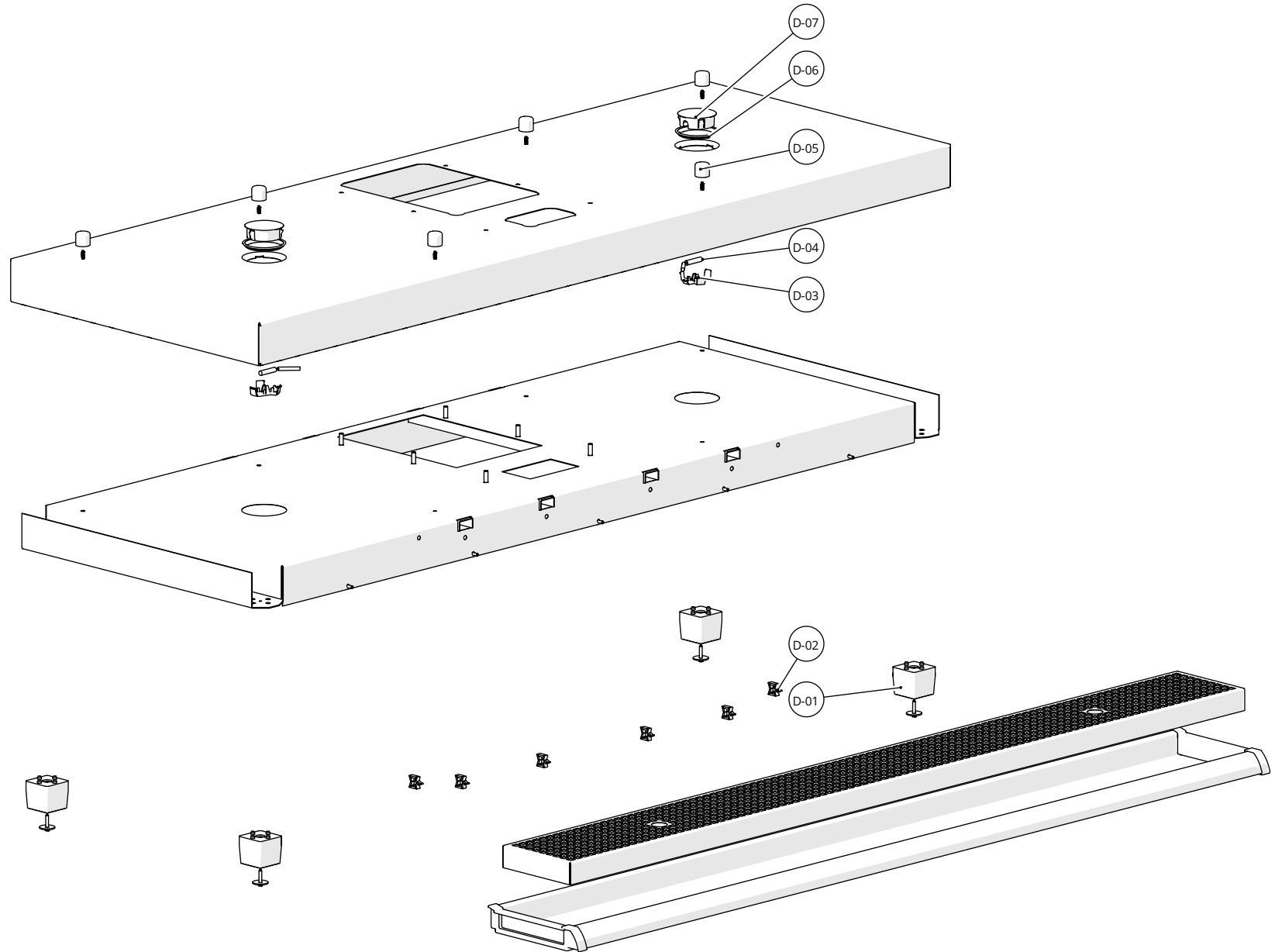

ID	Service parts	S-RS	Description
E-01	6.248.133.001	S	Handle VHG 40
E-02	6.240.145.001	S	Knob lid
E-03	6.006.001.101	S	Cord inlet with pull relief
E-04	6.311.196.001	S	Magnet support
E-05	6.017.003.006	S	Magnet
E-06	6.004.001.081	RS	Switch
E-07	6.240.139.001	S	Cord support
E-08	6.011.001.055	RS	O-ring 24x2
E-09	6.248.139.000	RS	PTC element VHG 40
E-10	6.248.130.000	S	Inner urn
E-11	6.240.134.001	S	Cap gauge glass
E-12	6.248.131.001	S	Case for gauge glass VHG 40
E-13	6.248.137.001	S	Strip for gauge glass VHG 40
E-14	6.248.132.001	S	Gauge glass VHG 40
E-15	6.011.001.112	S	O-ring 12x3
E-16	6.015.001.366	S	Upper part for tap
E-17	6.242.191.001	S	Tap handle
E-18	6.242.183.001	S	Screw cap tap housing
E-19	6.015.001.027	RS	Spring
E-20	6.015.001.281	S	Lever rod tap
E-21	6.015.001.006	RS	Rubber cup
E-22	6.242.187.001	S	Tap cover VHG 10 / 20 / 40
E-23	6.242.181.001	S	Tap housing VHG10/20/40
E-24	6.011.001.057	RS	O-ring 14x3.5

